

310gw±3%

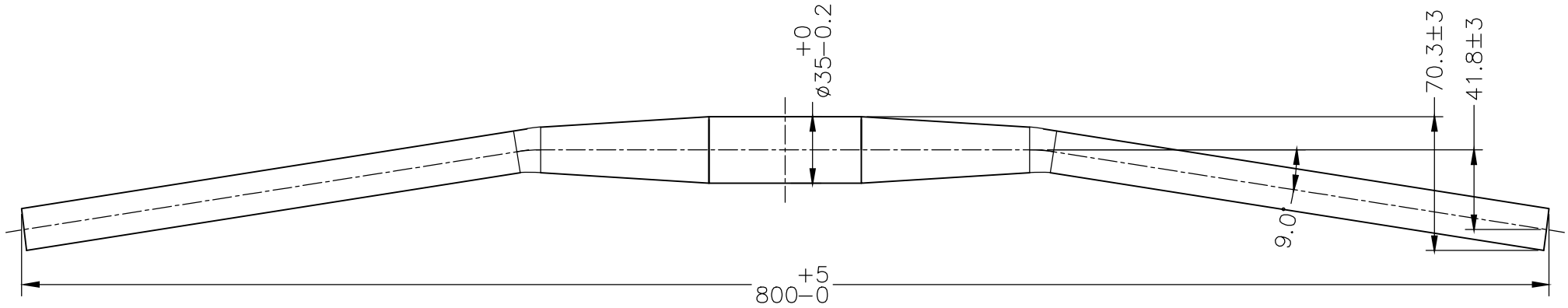

Ø35 TAPER Ø22.2 x 100L

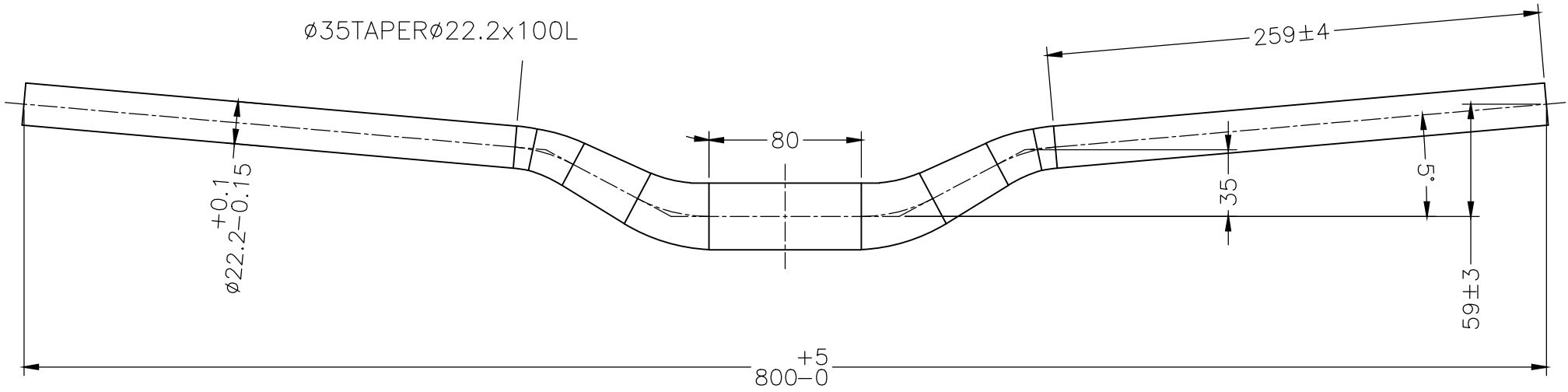

THIS DOCUMENT/DATA RECORD IS THE PROPERTY OF L.H. THOMSON CO. AND CONTAINS PROPRIETARY AND CONFIDENTIAL INFORMATION, AND IS NOT TO BE COPIED.

UNLESS OTHERWISE SPECIFIED DIMENSIONS ARE IN mm TOLERANCES:  
 ANGLES ± 1° DECIMALS ± .25  
 FINISH 3.2 RA MAX  
 BREAK CORNERS .30-.60 RAD

USED ON: L. H. Thomson Web Site		<b>L.H. THOMSON COMPANY</b> CORPORATE OFFICES MACON, GA 31297	
SECTION NO.		Thomson 35 x 35 x 800mm Bar	
CHANGE NO.	SIZE	CAGE CODE	DRAWING NO.
GROUP ORIGIN	A		
SHEET 1 OF 1			