

REV.	DATE	DESCRIPTION	APP.
A	3/25/08	REMOVED NONEXISTENT PART #s	ERL
B	3/26/10	ADDED 30.0 SB INFO	ERL
C	6/24/11	ADDED 27.2 x 367 SB INFO	ERL
D	12/11/12	UPDATED DIAMETERS TO MATCH NOMINAL SIZES	ERL
E	10/30/15	UPDATED PARTS TABLE	CJ

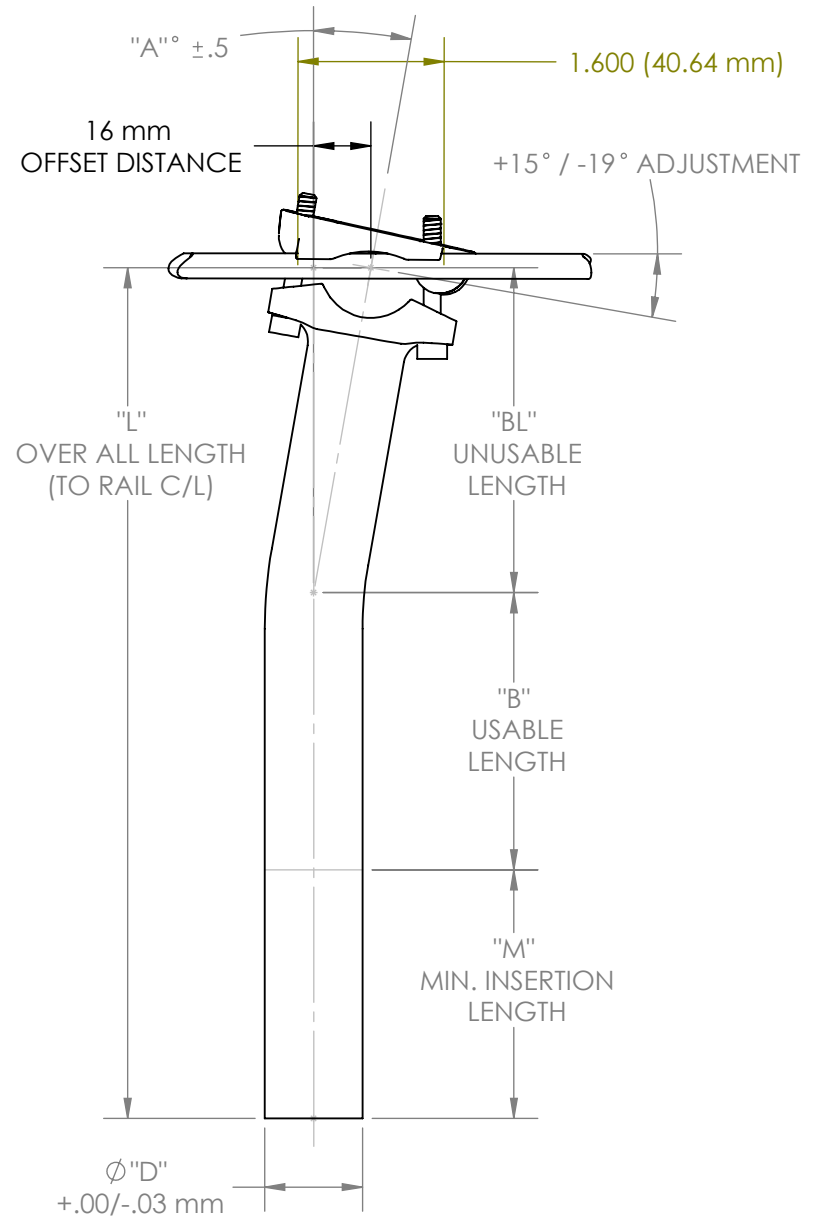

Model Number	DESCRIPTION	"L"	"M"	"A"	"B"	"BL"	"D"
		Over All Length	Min. Insertion Length	Setback	Usable Length	Unusable Length	Seatpost Diameter
SP-E105SB	26.8 x 330 mm SB	328.63 mm	63.50 mm	16 mm	168.08 mm	97.05 mm	26.8 mm
SP-E101SB	27.2 x 330 mm SB	328.63 mm	63.50 mm	16 mm	168.08 mm	97.05 mm	27.2 mm
SP-E102SB	27.2 x 250 mm SB	248.64 mm	63.50 mm	16 mm	88.09 mm	97.05 mm	27.2 mm
SP-E122SB	28.6 x 330 mm SB	328.63 mm	63.50 mm	16 mm	168.08 mm	97.05 mm	28.6 mm
SP-E127SB	30.9 x 410 mm SB	408.64 mm	100.00 mm	16 mm	198.22 mm	110.42 mm	30.9 mm
SP-E128SB	30.9 x 367 mm SB	365.13 mm	100.00 mm	16 mm	154.71 mm	110.42 mm	30.9 mm
SP-E109SB	31.6 x 367 mm SB	365.13mm	100.00 mm	16 mm	154.71 mm	110.42 mm	31.6 mm
SP-E113SB	27.2 x 410 mm SB	408.64 mm	75.00 mm	16 mm	223.22 mm	110.42 mm	27.2 mm
SP-E116SB	31.6 x 410 mm SB	408.64 mm	100.00 mm	16 mm	198.22 mm	110.42 mm	31.6 mm
SP-E155SB	32.4 x 367 mm SB	365.13 mm	100.00 mm	16 mm	154.71 mm	110.42 mm	32.4 mm
SP-E149 SB	30.0 x 410 mm SB	408.64 mm	100.00 mm	16 mm	198.22 mm	110.42 mm	30.0 mm

THIS DOCUMENT/DATA RECORD IS THE PROPERTY OF L.H. THOMSON CO. AND CONTAINS PROPRIETARY AND CONFIDENTIAL INFORMATION, AND IS NOT TO BE COPIED UNLESS OTHERWISE SPECIFIED DIMENSIONS ARE IN INCHES (mm) TOLERANCES:  
 ANGLES ± 1° DECIMALS ± .010 (.25)  
 FINISH 125 (3.2) RA MAX  
 BREAK CORNERS .01-.02 RAD

USED ON: L.H. Thomson Web Site	DRAWN: E.Lassiter	DATE: 12/19/06	<b>L.H. THOMSON COMPANY</b> CORPORATE OFFICES MACON, GA 31297		
SECTION NO.	CHECKED:	DATE:			
CHANGE NO.	STRESS:	DATE:	<b>ELITE SET BACK SEATPOST SIZE DIAGRAM</b>		
GROUP ORIGIN:	ENGR:	DATE:			
	M.E.:	DATE:	SIZE	CAGE CODE	DRAWING NO.
	GROUP:	DATE:	WEB 002		
	PROJ.:	DATE:	SHEET 1 OF 1		